

Data Sheet - AXION™ THERMAL JACKET

Style MM1550VTAC01

McAllister Mills, Inc.

Revised: Feb. 8, 2019R00

1	REINFORCED VINYL OR PTFE FABRIC
2	MM10ACLF48 EPDM INSULATION
3	1 1/2" W. POLYESTER BELT
4	1 1/2" SS D-RING
5	2" W LOOP VELCRO
6	2 1/2" W FLAP w/ 2" HOOK VELCRO
7	2" W DRAWCORD FLAP w/ 1/8" TEFLON COATED BRAIDED CORD

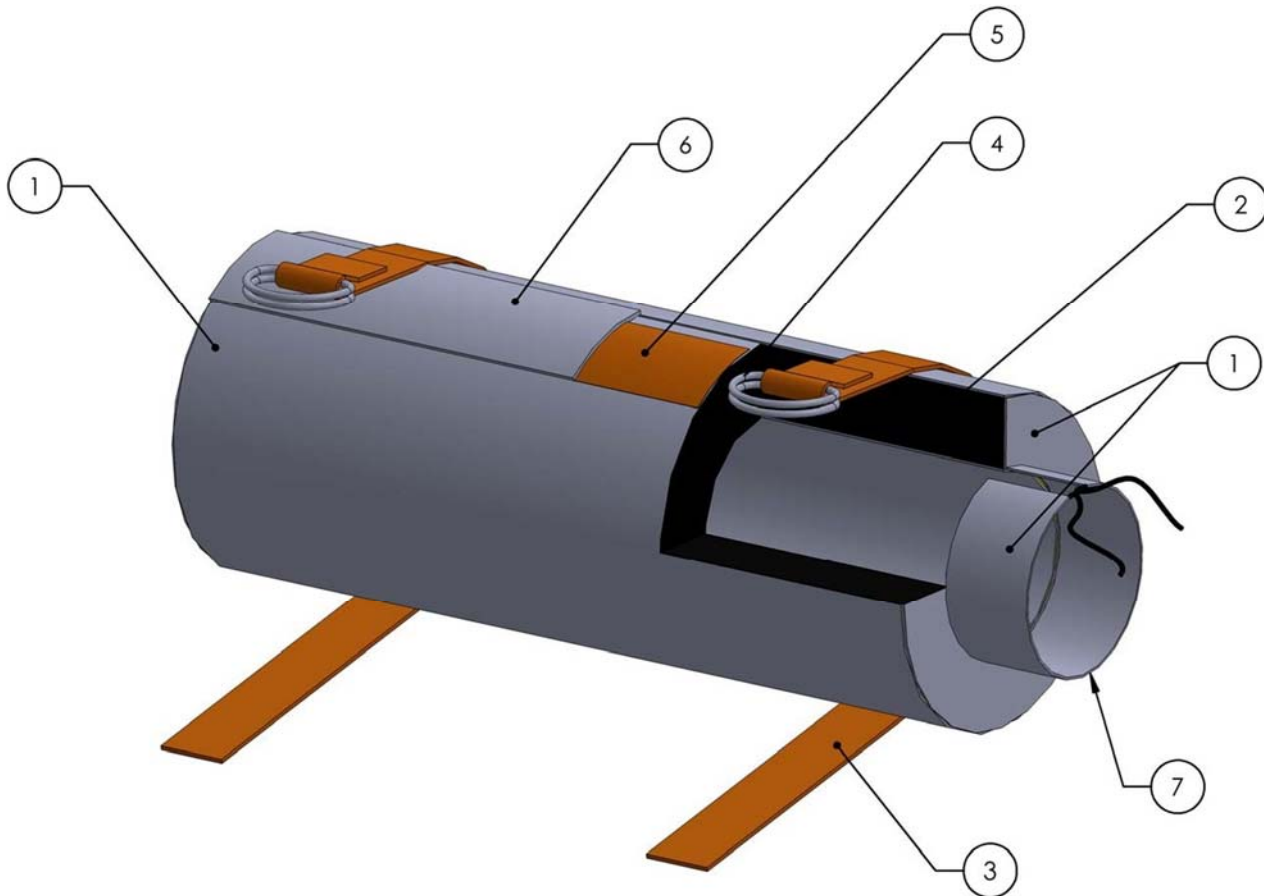

Blanket Construction: Blanket construction is completely machine sewn and lock-stitched at minimum 6-7 stitches per inch. 2 1/2" hook/loop flap fasteners with 1 1/2" D-ring polyester belts. PTFE coated drawcord at pipe penetrations.

Design: Jackets are custom measured and constructed to fit surface geometry using a 3D tailored or molded approach as opposed to flat blankets. 3D modeling is used to design and flatten fabric surfaces.

Data Sheet - AXION™ THERMAL JACKET

Style MM1550VTAC01

McAllister Mills, Inc.

Revised: Feb. 8, 2019R00

Blanket Weight: No individual section will exceed 35lbs

Blanket Overlap: Jacket will extend a minimum of 2” over adjacent surface when feasible.

Product Type: Coated vinyl or PTFE fabric outer shell and closed cell EPDM with integrated low .2 perm vapor barrier for superior moisture and UV resistance.

Style: MM1550VTAC01

Weight: 12 oz/ft² (ounces/sq.ft.)

Thickness: 1.0” (inches)

Filler: MM10ACLF48

Temperature: -40°F to 300°F

Product Description: Tough, strong, and built for heavy industrial abuse. Textile Engineered and tested with optimum weight for durability and thermal protection, but yet light enough to install with ease. Full contoured fit and optimized for maximum heat retention. A high performance, cost effective, dual temperature insulation jacket. MM1550VTAC01 can “deliver value and savings” only available from a lean vertically integrated textile manufacturer.

Applications:

- Industrial removable covers.
- Piping Components
- Valves and Flanges
- Pumps
- Tanks

